

Cleanliness Without Compromise

Hako



PowerBoss®
The Power of Clean

Nautilus

Industrial Scrubber Sweeper

Command the Floor. Clean with Power and Purpose

High Performance Industrial Cleaning Results

Easy Access Panels
Lightweight rotomoulded panels, allowing for ease of serviceability

Squeegee
Industrial-grade chemical resistant



Stainless Steel Hopper
Easy roll casters for easy removal

Stainless Steel Scrubbing Deck
152cm Scrubbing Sweeping Path

Military Grade E-Coated
Weatherproof steel frame

Reliable Kubota Powered
LPG or Diesel



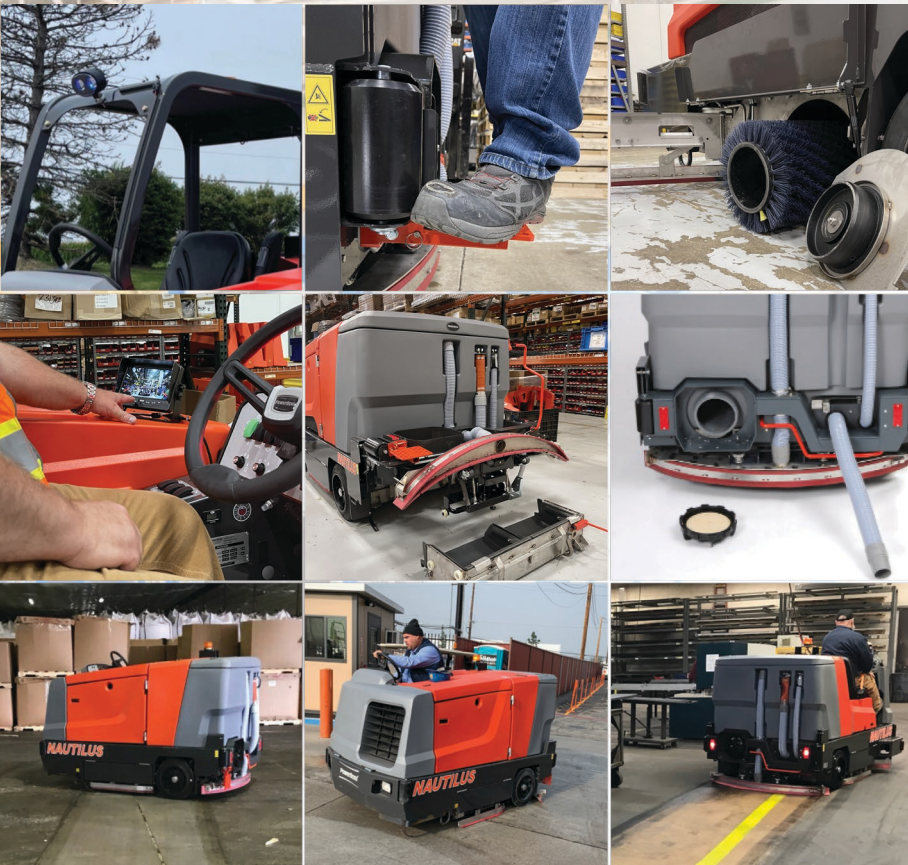

Options and additional machine benefits

- **Optional Safety Features**
Overhead guard with blue spotlight
- **Integrated Step**
Allows for easy clean-out of the recovery tank
- **No Tools Required**
Easy change access to the 114cm cylindrical brush with yellow wear indicator
- **Optional Reversing Camera**
with LCD screen
- **Stainless Steel Construction**
Debris hopper, scrub deck and hardware provide long machine life
- **Oversized Clean Out Port**
Allows easy removal of built-up sediment
- **Versatile Outdoor Cleaning Applications**
Clean and safe floors in a single pass

Innovative On-board Hot Water Cleaning Technology (TGT)

How It Works

- 1.) Water is pumped through the heat exchanger
- 2.) Exhaust from the engine is routed to the heat exchanger
- 3.) The heat exchanger raises the water temperature 70+ degrees
- 4.) The heated water is evenly distributed to the scrub deck

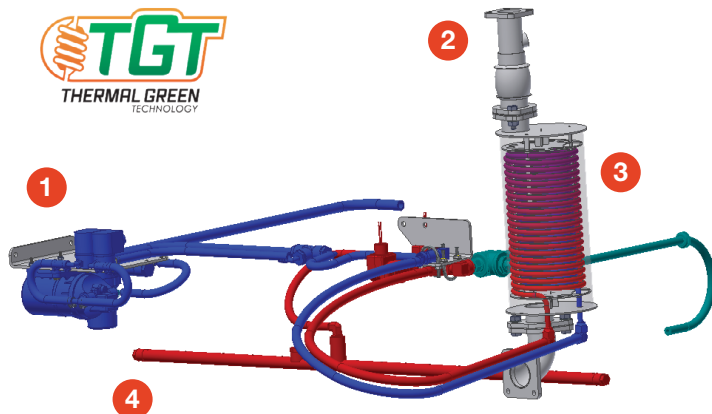
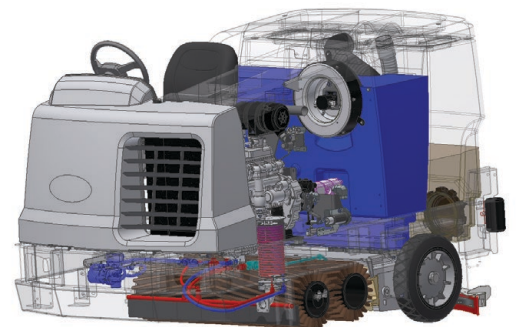

- Allows for "Chemical Free" cleaning on non-oily floors
- Enhances chemical performance on oily floors using less chemical
- Provides green and sustainable cleaning
- No additional cost, using the heat being generated by the engine

Technical data

	Technical data: NAUTILUS
Integrated Cleaning System	<ul style="list-style-type: none"> • Cleaning path: 1143mm - With Scrubbing Side Brush: 1524mm - With Sweeping Side Brush: 1574mm
Cylindrical Main Brushes	<ul style="list-style-type: none"> • Brush Speed: 425rpm • Brush Down Pressure (up to): 181.4kg • Brush Diameter (2): 300mm
Disc Main Brushes	<ul style="list-style-type: none"> • Brush Speed: 225rpm • Scrub Brush Diameter (3): 406.4mm
Side Brush	<ul style="list-style-type: none"> • Brush Speed: 200rpm
Tanks	<ul style="list-style-type: none"> • Solution Tank: 397.4 L • Recovery Tank: 397.4 L • Demisting Chamber: 64.3 L
Debris Hopper	<ul style="list-style-type: none"> • Volume Capacity: 59 L
Vacuum Fan	<ul style="list-style-type: none"> • Scrubbing Fan Speed: 11,500rpm • Scrubbing Fan Water Lift: 889mm
Engine and Gradeability	<ul style="list-style-type: none"> • Engine LPG (1.5L): 1.5 litre Kubota WG1605L <ul style="list-style-type: none"> - Gross Intermittent Power: 3600rpm - PowerBoss Governed Power: 2400rpm • Engine Diesel (1.5L): 1.5 litre Kubota V1505 <ul style="list-style-type: none"> - Gross Intermittent Power: 2300rpm - PowerBoss Governed Power: 2300rpm • Gradeability <ul style="list-style-type: none"> - Transport at Gross Weight: 10 degrees - Working (cleaning): 8 degrees
Machine Specifications	<ul style="list-style-type: none"> • Length: 2413mm • Width: 1350mm • Frame: 1397mm <ul style="list-style-type: none"> - Rear Squeegee: 1422mm - Wide Side Brush: 1663mm • Height <ul style="list-style-type: none"> - At Lowest Steering Wheel Position: 1536mm - With Overhead Guard: 2120mm • Weight (empty): 1,474kg <ul style="list-style-type: none"> - Weight (GVW): 2,177kg - Minimum Aisle Turn: 2735mm



Our Blue initiatives meet Green cleaning standards, but provide even more features specific to industrial applications and environments. Water conservation, clean air, clean energy, lower chemical reliance, lower emissions and a safer work environment are just a few of the Blue hallmarks

PowerBoss
The Power of Clean

*PowerBoss is subsidiary of the HAKO Group.

Hako

Hako Australia

90 Wetherill St, Silverwater NSW, 2128

Phone: 1800 257 221

hksales@hakoaustralia.com.au

www.hakoaustralia.com.au